

**Wi-Fi Mesh Module**  
**WF88**

Amp'ed RF Technology, Inc.

## WF88 Product Specification



### Description

Amp'ed RF Tech presents the WF88 Wi-Fi dual band, 2.4/5GHz IoT module. The WF88 is a small footprint low cost RF module, supporting IPV6 and Mesh networking 300m range line-of-sight. Intended to help customers shorten product development cycles and reduce cost, this module is ready to go. Typical applications include:

- Remote metering
- IoT applications
- Mesh networks
- Smart home control
- Industrial control

### Features

#### Hardware

- Wi-Fi: ACC1340
- Linux CPU
- WF88-EX: 24mm x 20mm
- SDIO/ethernet/USB/I2C

#### WLAN

- 802.11a/b/g/n
- Dual Band: 2.4/5GHz
- Output Power, +21dBm
- IPV6
- Mesh networking
- Security: WPA3
- OTA/OTAP support

## Contents

<b>1. Hardware Specifications</b> .....	<b>4</b>
1.1. Recommended Operating Conditions .....	4
1.2. Absolute Maximum Ratings .....	4
1.3. I/O Operating Conditions.....	4
1.4. Current Consumption .....	5
1.5. Selected RF Characteristics.....	5
1.6. Pin Assignment .....	5
<b>2. Module Drawing</b> .....	<b>8</b>
<b>3. Reference Design Circuits</b> .....	<b>9</b>
<b>4. Ordering Information</b> .....	<b>11</b>
<b>5. Revision History</b> .....	<b>12</b>

## 1. Hardware Specifications

General Conditions 25°C

### 1.1. Recommended Operating Conditions

Rating	Min	Typical	Max	Unit
Operating Temperature Range	-20	-	70	°C
Supply Voltage VDD	3.0	3.3	3.6	Volts
Supply Voltage VDD_PA	3.15	3.9	5.0	Volts
Signal Pin Voltage	-	3.3	-	Volts
RF Frequency for 2.4G	2400	-	2483.5	MHz
RF Frequency for 5G	5150	-	5850	MHz

### 1.2. Absolute Maximum Ratings

Rating	Min	Typical	Max	Unit
Storage temperature range	-40	-	+80	°C
Supply Voltage VDD	-0.3	-	+4.8	Volts
Supply Voltage VDD_PA	-0.3	-	+5.5	Volts
I/O pin voltage VIO	-0.3	-	+4.8	Volts
RF input power	-	-	-5	dBm

### 1.3. I/O Operating Conditions

Symbol	Parameter	Min	Max	Unit
V <sub>IL</sub>	Low-Level Input Voltage	-	1.2	Volts
V <sub>IH</sub>	High-Level Input Voltage	2.2	-	Volts
V <sub>OL</sub>	Low-Level Output Voltage	-	0.2	Volts
V <sub>OH</sub>	High-Level Output Voltage	2.95	-	Volts
I <sub>OL</sub>	Low –Level Output Current	-	4.0	mA
I <sub>OH</sub>	High-Level Output Current	-	4.0	mA

#### 1.4. Current Consumption

VDD=3.3V VDD_AP=3.3V	Avg	Unit
Standby	2	mA
Active	140	mA
I <sub>peak</sub> : system maximum peak current draw	300	mA

#### 1.5. Selected RF Characteristics

Parameters	Conditions	Typical	Unit
Antenna load		50	ohm
<b>Wi-Fi Receiver 5GHz 11n</b>			
Sensitivity	BPSK 6.5Mbps@PER<10%,Nss=1	-91	dBm
Sensitivity	QPSK 13Mbps@PER<10%, Nss=1	-88	dBm
Sensitivity	16QAM 26MbpsPER<10%,Nss=1	-83	dBm
Sensitivity	64QAM 65MbpsPER<10%,Nss=1	-72.5	dBm
<b>Wi-Fi Transmitter 5GHz, 11n</b>			
Output Power	802.11n MCS-1	21	dBm

#### 1.6. Pin Assignment

Assignment	Type	Pin #	Description
GND		1	
VDD		2	Supply in 3.3V
USB_DP	I/O	3	USB
USB_DM	I/O	4	USB
BOOT	I/O	5	
UART0_RTS	I/O	6	UART RTS
UART0_CTS	I/O	7	UART CTS
UART0_TXD	I/O	8	UART TXD
UART0_RXD	I/O	9	UART RXD
UART1_RXD	I/O	10	UART RXD, debug serial port
UART1_TXD	I/O	11	UART TXD, debug serial port

GMAC_TXEN	I/O	12	
GMAC_TXD1	I/O	13	
GMAC_TXD0	I/O	14	
GMAC_PHY_CLK	I/O	15	
GMAC_TXCLK	I/O	16	
GMAC_RXD1	I/O	17	
GMAC_RXD0	I/O	18	
GMAC_CRS_DV	I/O	19	
GMAC_MDC	I/O	20	
GMAC_MDIO	I/O	21	
GPIO0	I/O	22	
GPIO1	I/O	23	
GMAC_RST_N/PWM1/GPIO2	I/O	24	PWM
PWM2/GPIO3	I/O	25	PWM
I2C_SCK/GPIO4	I/O	26	I2C clock
I2C_SDA/GPIO5	I/O	27	I2C data
GPIO6	I/O	28	GPIO
GPIO7	I/O	29	GPIO
RESET		30	
LPCLK_1V8		31	Low power clock input
VDD_PA		32	Supply in 3.9V
GND		33	
GND		34	
2.4G_ANT	RF	35	Optional RF port
GND		36	
GND		37	
5G_ANT	RF	38	Optional RF port
GND		39	
1V8_OUT		40	
ADC_VREF		41	Voltage reference input, 0.9~1.8V.
ADC_IN		42	Analog input

**Note:**

1V8\_OUT, it can only provide reference for ADC, when the user does not need other values of the ADC\_VREF or more stable and accurate ADC\_VREF. 1V8\_OUT cannot power other circuits.

## 2. Module Drawing

Size: 24 mm x 20 mm x 2.8 mm

Top view

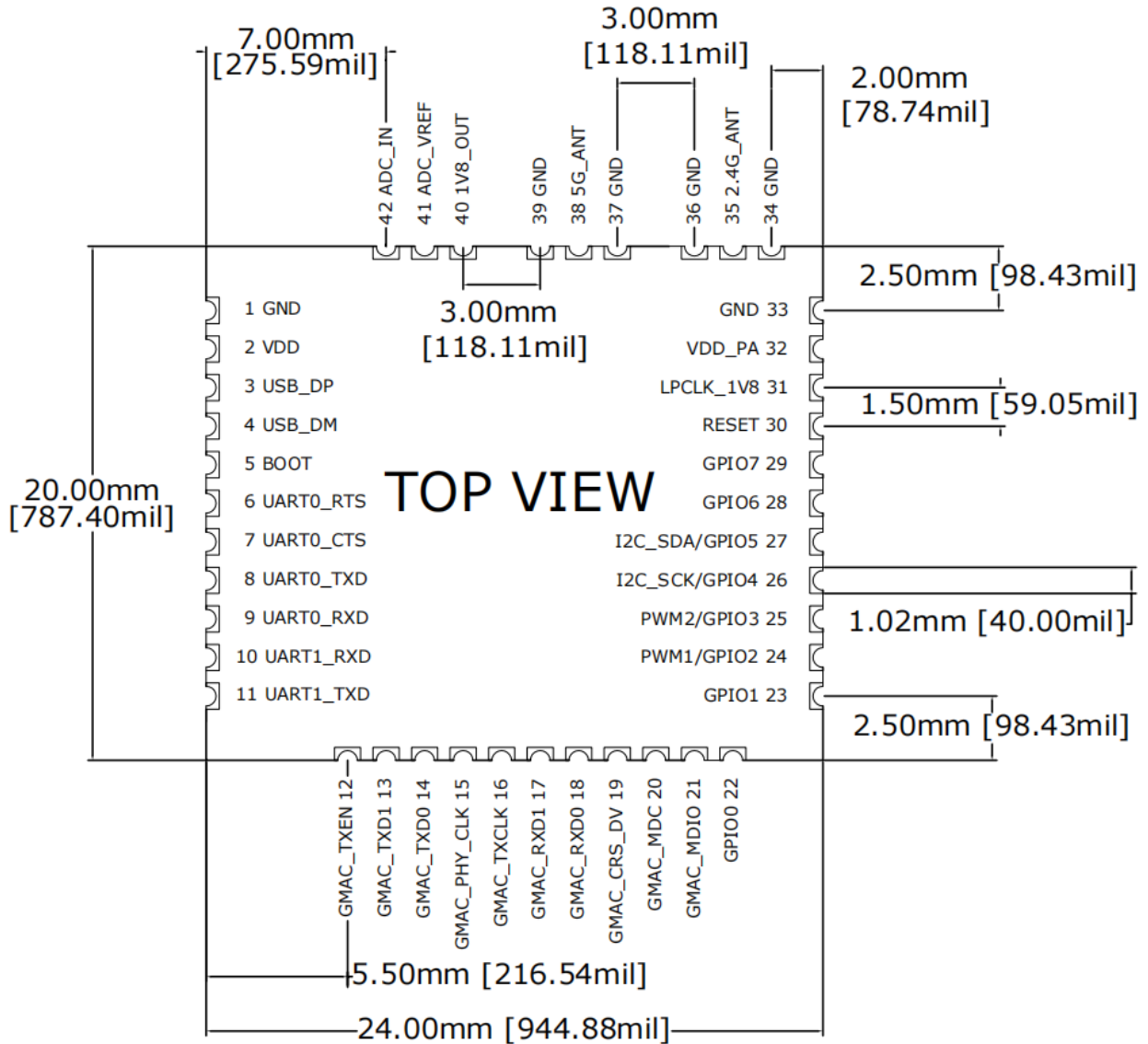



### 3. Reference Design Circuits

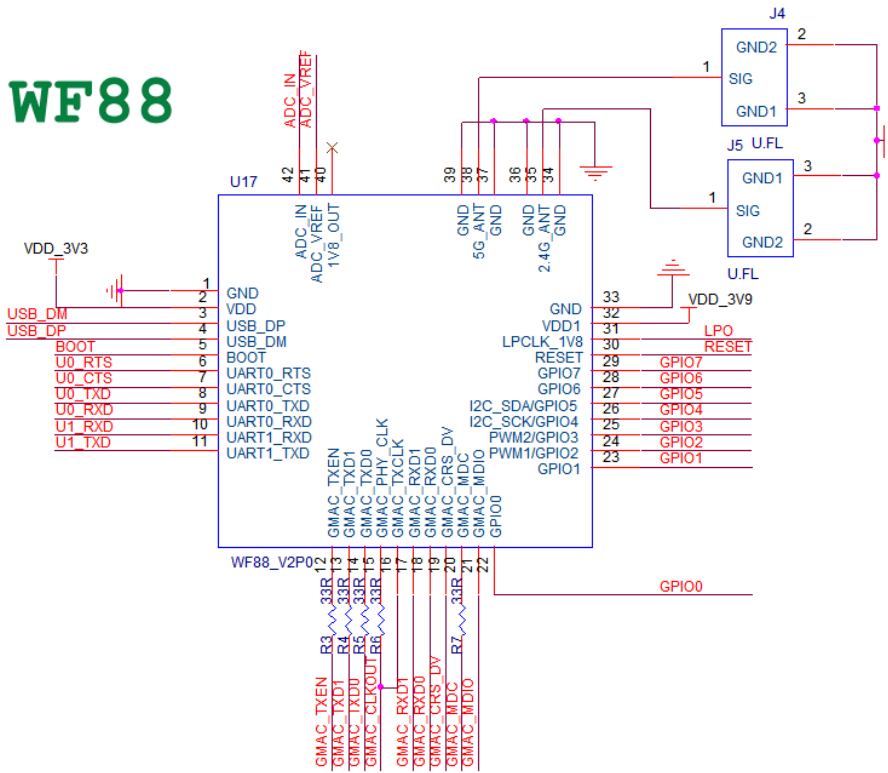

ADC:

- When using an external reference voltage, do not connect 1V8\_OUT.
- If there is no external reference voltage, connect ADC\_VREF AND 1V8\_OUT.

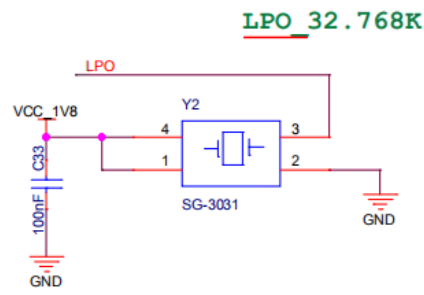
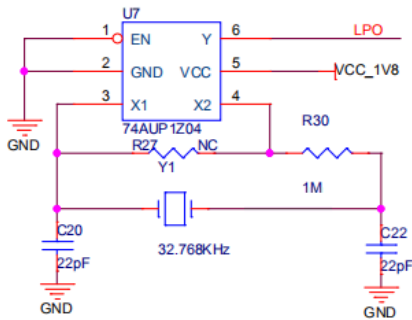



#### 4. Ordering Information

Part Name	Description
WF88-A	Wi-Fi module, dual band, with U.FL antenna connectors (No longer available)
WF88-EX	Wi-Fi module, dual band, with external antenna ports
WF88M-EX	Wi-Fi module, dual band, with embedded MCU, external antenna ports

## 5. Revision History

Date	Revision	Description
3/24/2023	1.0	Initial release
5/25/23	1.1	Add console password
3/28/2024	2.0	Updated module pinout and size. Added new part number options